

Table II. List of Atomic Positions

Atom	X	Y	Z	Atom	X	Y	Z
Nd _I	0.5194	0.2426	0.1085	C(17)	0.9403	0.2922	0.0505
Nd _{II}	0.8282	0.3143	0.1498	C(18)	0.8743	0.2168	0.0152
C(1)	0.3581	0.1893	0.0151	C(19)	0.8343	0.1381	0.0490
C(2)	0.3697	0.1549	0.1084	C(20)	0.8408	0.1080	0.1456
C(3)	0.4030	0.1948	0.1939	C(21)	0.8988	0.1415	0.2478
C(4)	0.4342	0.2912	0.2350	C(22)	0.9628	0.2255	0.2778
C(5)	0.4509	0.3892	0.1933	C(23)	0.9939	0.2984	0.2294
C(6)	0.4456	0.4167	0.1059	C(24)	0.9906	0.3262	0.1407
C(7)	0.4136	0.3932	0.0104	O(1)	0.8467	0.4666	0.2735
C(8)	0.3778	0.2850	-0.0262	C(25)	0.7827	0.5492	0.2671
C(9)	0.6056	0.1086	0.0227	C(26)	0.8308	0.6396	0.3324
C(10)	0.6177	0.0659	0.1160	C(27)	0.9021	0.5794	0.4096
C(11)	0.6498	0.1061	0.2101	C(28)	0.9271	0.4916	0.3532
C(12)	0.6777	0.2038	0.2525	O(2)	0.8143	0.4845	0.0511
C(13)	0.6815	0.3077	0.2158	C(29)	0.8779	0.5699	0.0773
C(14)	0.6628	0.3570	0.1189	C(30)	0.8471	0.6503	-0.0013
C(15)	0.6421	0.3144	0.0269	C(31)	0.7969	0.5915	-0.0899
C(16)	0.6167	0.2111	-0.0141	C(32)	0.7707	0.4884	-0.0549

tion sphere about Nd_{II} consists of ring 3, average Nd-C distance of 2.673 (16) Å, together with the two THF oxygen atoms, average Nd-O distance of 2.577 (11) Å, and part of ring 2. In particular C(14) is definitely in the coordination sphere of Nd_{II} and C(13) and C(15) may well be. The Nd_{II}-C(14) distance is 2.700 (18) Å while those of Nd_{II}-C(13) and Nd_{II}-C(15) are 2.896 (20) and 3.059 (19) Å, respectively.

The geometry of the Nd(COT)₂⁻ anion is unique for all known lanthanide and actinide COT compounds.³⁻⁶ The 0.1 Å difference in the average Nd-C distances for rings 1 and 2 and the 8.25° angle of intersection between the planes of rings 1 and 2 make the anion the first example of a lanthanide or actinide asymmetric M(COT)₂ unit. Also the position of ring 2 relative to Nd_{II} is the first example of a lanthanide or actinide asymmetrically bonded to a COT²⁻ ring. This additional coordination is, however, known for lanthanide cyclopentadienide compounds. For example, the crystal structure of neodymium tris(methylcyclopentadienide) shows both η_1 Nd-C and η_5 Nd-C interactions.⁷ The η_1 Nd-C bond lengths, 2.990 and 2.978 Å, are about 0.2 Å greater than the average of the η_5 bonds. Both Sc(C₅H₅)₃⁸ and Sm(C₅H₅)₃⁹ also show η_5 and η_1 metal cyclopentadienide coordination.

Other interesting features are noted in comparing the three COT²⁻ rings. Values of the standard deviation of bond lengths and angles, thermal parameters, and root-mean-square amplitudes of vibration are much less for ring 2 than for rings 1 and 3. Average standard deviations of the bond lengths and angles in ring 2 are 0.014 Å and 0.69° while in rings 1 and 3 they are 0.057 Å and 2.29° and 0.025 Å and 1.49°, respectively. Thermal parameters for ring 2 are only about one-half as large as the corresponding parameters for rings 1 and 3. The root-mean-square amplitudes of vibration for ring 2 are 0.137, 0.206, and 0.280 Å, while in rings 1 and 3 they are 0.139, 0.236, and 0.540 Å, and 0.138, 0.273, and 0.446 Å, respectively. These data clearly show that ring 2 is much more rigidly fixed in space than are rings 1 and 3. This does not seem surprising when one considers that ring 2 is asymmetrically bonded to Nd_{II} while rings 1 and 3 are both symmetrically bonded to the neodymiums.

Acknowledgment is made to the donors of the Petroleum Research Fund, administered by the American Chemical Society, to the Energy Research and Development Agency for partial support of this research, and to the Oregon State University Computer Center for its financial assistance. We are also indebted to Drs. Clara and David Shoemaker for

their assistance. We are grateful for the use of the remote terminal facility located in the Environmental Protection Agency, Corvallis, Oregon, and also to Dr. Allan Zalkin for permission to use his Library of Crystallographic Programs at the Lawrence Berkeley Laboratory.

References and Notes

- (1) See, for example, the review by P. L. Timms, *Adv. Inorg. Chem. Radi-chem.*, **14**, 121 (1972).
- (2) (a) K. O. Hodgson, F. Mares, P. F. Starks, and A. Streitwieser, *J. Am. Chem. Soc.*, **95**, 8650 (1973); (b) A. Streitwieser, U. Muller-Westerhoff, G. Sonnichsen, F. Mares, D. G. Morrell, K. O. Hodgson, and C. A. Harmon, *ibid.*, **95**, 8644 (1973).
- (3) K. O. Hodgson and K. N. Raymond, *Inorg. Chem.*, **11**, 171 (1972).
- (4) A. Avdeef, K. N. Raymond, K. O. Hodgson, and A. Zalkin, *Inorg. Chem.*, **11**, 1083 (1972).
- (5) K. O. Hodgson and K. N. Raymond, *Inorg. Chem.*, **11**, 3030 (1972).
- (6) K. O. Hodgson and K. N. Raymond, *Inorg. Chem.*, **12**, 458 (1973).
- (7) J. H. Burns, W. H. Baldwin, and F. H. Fink, *Inorg. Chem.*, **13**, 1916 (1974).
- (8) J. L. Atwood and K. D. Smith, *J. Am. Chem. Soc.*, **95**, 1488 (1973).
- (9) C. H. Wong, T. Lee and Y. Lee, *Acta Crystallogr., Sect. B*, **25**, 2580 (1969).

Stephen R. Ely, Ted E. Hopkins, Carroll W. DeKock*

Department of Chemistry, Oregon State University
Corvallis, Oregon 97331

Received November 24, 1975

Effect of Irradiation with Ultraviolet Light on Spectral Sensitization of the Photoelectrochemical Process of a Zinc Oxide Single-Crystal Electrode

Sir:

A number of reports have dealt with the spectral sensitization of photoelectrochemical reactions with dye molecules using semiconductor electrodes.¹⁻¹² For n-type semiconductor electrodes, when a sensitizing dye is added to the electrolyte solution, an increase in the anodic photocurrent occurs upon irradiation in the longer wavelength regions. These photocurrents show a spectral dependence which follows the absorption spectrum of the sensitizer. Two different mechanisms, one involving electron transfer and another involving energy transfer, have been proposed for the electrochemical spectral sensitization^{1,4,9} as well as for silver halide photography.¹³⁻¹⁵ The sensitized anodic photocurrent at a ZnO single-crystal electrode has been attributed predominantly to electron transfer from the excited dye molecule to the conduction band of ZnO.^{2,5-7,10-12}

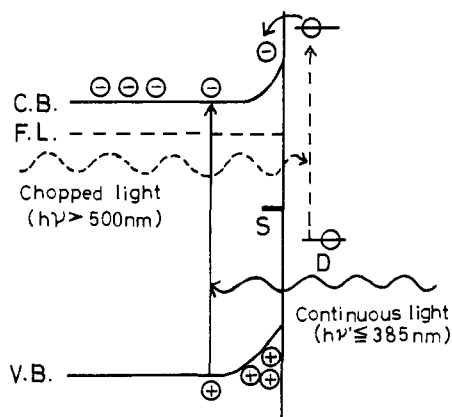

Figure 1. Schematic structure of the semiconductor electrode surface polarized anodically: D, dye molecule; S, surface electron donor level.

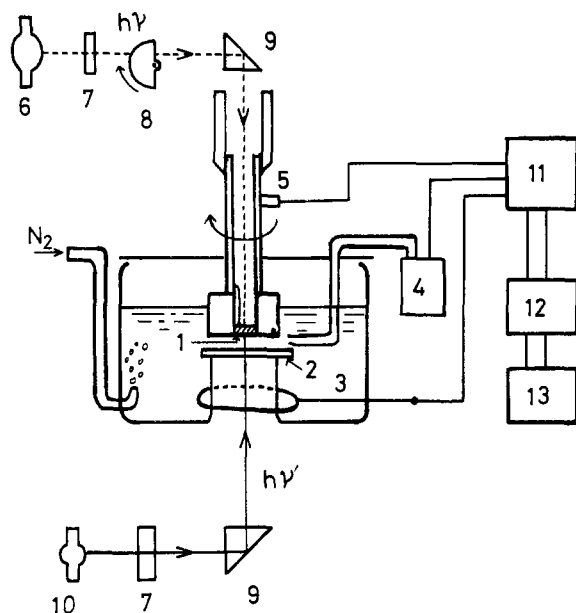

Figure 2. Measurement assembly: (1) ZnO electrode, (2) quartz plate, (3) platinum wire counter electrode, (4) saturated calomel electrode, (5) rotating electrode system, (6) 500-W xenon lamp, (7) interference filter or colored glass filter, (8) light chopper (8 Hz), (9) prism, (10) 270-W Hg lamp, (11) potentiostat, (12) lock-in amplifier, (13) recorder.

On the other hand, when shorter wavelength light (of energy greater than the band gap of an n-type semiconductor) irradiates the surface of a positively biased electrode, a dissolution reaction of the semiconductor occurs by the consumption of holes in the valence band created by the photoabsorption (for example, under ultraviolet irradiation, $\text{ZnO} + 2\text{p}^+ \rightarrow \text{Zn}^{2+} + \frac{1}{2}\text{O}_2$).¹⁶⁻¹⁹ In some cases, redox reactions occur between these holes and chemical species in the electrolyte.²⁰⁻²³ When these two reactions (i.e., the dye-sensitized and the dissolution reactions) proceed on the semiconductor surface at the same time, they may influence one another. For example, when the holes created in the valence band by the band-gap (ultraviolet) excitation can react with the dye adsorbed on the semiconductor surface, resulting in the oxidation of the dye molecule, the dye-sensitized current may decrease. On the other hand, if donor levels which can donate electrons to the excited or oxidized dyes are formed on the semiconductor surface in the course of the dissolution reaction initiated by irradiation with the ultraviolet light, the spectrally sensitized reaction rate may increase.

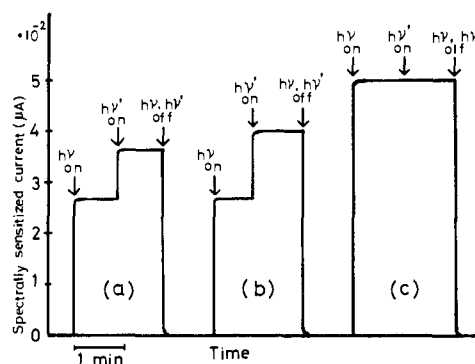

Figure 3. Increase of the spectrally sensitized current by superimposing continuous irradiation with ZnO-exciting light: rhodamine B: 10^{-3} M (0.1 M KCl); $h\nu$, chopped dye-exciting light; $h\nu'$, continuous ZnO-exciting light; intensity of $h\nu$, (a) = (b) = (c); intensity of $h\nu'$, (a) < (b) = (c); (a, b), absence of hydroquinone; (c), hydroquinone (10^{-2} M).

In the present study, the dye-sensitized current was measured separately from the dissolution current by irradiating a ZnO electrode simultaneously with continuous light of short wavelength ($h\nu'$) (corresponding to the band gap) and chopped light of a longer wavelength ($h\nu$) (corresponding to the dye absorption spectrum). A schematic illustration of this method at the ZnO electrode is shown in Figure 1. The zinc oxide single crystal, generously donated by the 3M Company (surface area, 0.3 cm^2 ; thickness, 1.5 mm; carrier density, $7.5 \times 10^{16} \text{ cm}^{-3}$) was used as the semiconductor electrode, and rhodamine B the sensitizing dye. The actual measurement assembly is shown in Figure 2. The ZnO disk electrode was rotated at a speed of about 800 rpm. Excitation of the dye adsorbed on the ZnO was carried out by irradiation with light chopped at 8 Hz passed down the steel tube of the rotating disk electrode and through the ZnO crystal itself. The light source was a 500-W xenon lamp. The ZnO itself was irradiated with uv light via a quartz window and through the dye-containing electrolyte solution (0.1 M KCl) using a high-pressure 270-W mercury lamp. The wavelength of the illuminating light was selected with interference or colored glass filters. The potential of the ZnO electrode was controlled with a potentiostat, and a lock-in amplifier, Model LA-126, (Nihon Bunko Co.), was employed for measurement of the modulated current.

Under irradiation with light of wavelengths shorter than 385 nm, the dissolution reaction of the ZnO electrode occurs with a high quantum efficiency.¹⁶⁻¹⁹ When sensitizing dyes were added to the electrolyte solution, the current corresponding to the wavelength of the chopped light measured by the lock-in amplifier increased in accordance with the absorption spectrum of the dye solution. The wavelength corresponding to the maximum modulated current was 560 nm, which is nearly identical with the absorption maximum of the rhodamine B solution.

The effect of continuous irradiation with short wavelength light on the spectrally sensitized current is shown in Figure 3. As can be seen from curves (a) and (b) in Figure 3, the sensitized current is increased by the additional continuous irradiation. When the short wavelength light intensity was increased, the dissolution current became larger, and so did the modulated sensitized current. However, at a certain level of the short wavelength light intensity the spectrally sensitized current attained a constant saturated value. When the energy of the continuous light was not sufficient to excite the electrons in the valence band of ZnO, the modulated sensitized current did not increase, even for high intensities of the continuous light.

It has often been observed that the spectrally sensitized

current is increased by addition of reducing agents such as hydroquinone.¹⁻¹² This behavior, termed supersensitization, is based on the donation of electrons by the reducing agents to the excited or oxidized dyes. The reducing agents are, therefore, oxidized in the supersensitization process, as has been demonstrated experimentally by the rotating ring-disk electrode technique.²⁴ The effect of excitation with short wavelength light on the spectrally sensitized currents in the presence of a reducing agent was also investigated. When hydroquinone was added to the dye-containing solution, the spectrally sensitized current increased as expected. However, additional irradiation with the continuous ultraviolet light in the presence of hydroquinone showed no detectable effect (Figure 3c). This suggests that the irradiation with ultraviolet light and the supersensitization by the reducing agent are competitive with respect to increasing the modulated sensitized current at the ZnO electrode. During the dissolution reaction of ZnO, electron donor levels may be formed on the surface (such as surface levels of O⁻, O₂⁻, or O₂²⁻)¹⁶⁻¹⁸ which may be able to play the same role as the reducing agent, i.e., to supply electrons continuously to the excited or oxidized dye molecule. Note that although the current resulting from this donation of electrons from the electrode to the dye is a cathodic one, it does not contribute to the modulated anodic spectrally sensitized photocurrent. The hydroquinone, which can act as a strong supersensitizer, may compete with the electron transfer to the dye by the surface electron donor levels. Another possible reason for the lack of an effect of the continuous ultraviolet light in the presence of hydroquinone is that the formation of the surface electron donor levels (O⁻, O₂⁻, or O₂²⁻) is prevented by the suppression of the anodic dissolution reaction because of a reaction between the holes in the valence band and the hydroquinone.¹⁸

These experiments suggest that surface states on a ZnO semiconductor electrode are involved in dye spectral sensitization. It is known that the spectral sensitization plays an important role in the silver halide photographic system. By analogy with the photographic process, photoelectrochemical studies can be expected to contribute to the elucidation of spectral sensitization in photography. Similar investigations using silver halide electrodes are now in progress.

References and Notes

- H. Gerischer and H. Tributsch, *Ber. Bunsenges. Phys. Chem.*, **72**, 437 (1968).
- H. Tributsch and H. Gerischer, *Ber. Bunsenges. Phys. Chem.*, **73**, 251, 850 (1969).
- H. Tributsch and M. Calvin, *Photochem. Photobiol.*, **14**, 95 (1971).
- H. Gerischer and H. Seizle, *Electrochim. Acta*, **18**, 799 (1973).
- B. Pattinger, H. R. Schoppel, and H. Gerischer, *Ber. Bunsenges. Phys. Chem.*, **77**, 960 (1973).
- K. Hauffe, V. Martinez, J. Range, and R. Schmidt, *Photogr. Korresp.*, **104**, 113 (1968).
- K. Hauffe, H. J. Danzmann, H. Pusch, J. Range, and H. Volz, *J. Electrochem. Soc.*, **117**, 993 (1970).
- U. Bode, K. Hauffe, and H. Pusch, *Ber. Bunsenges. Phys. Chem.*, **77**, 966 (1973).
- R. Memming and H. Tributsch, *J. Phys. Chem.*, **75**, 562 (1971).
- A. Fujishima, E. Hayashitani, and K. Honda, *Seisan Kenkyu*, **23**, 31, 363 (1971).
- A. Fujishima, T. Watanabe, O. Tatsuoki, and K. Honda, *Chem. Lett.*, **13** (1975).
- T. Watanabe, A. Fujishima, O. Tatsuoki, and K. Honda, *Bull. Chem. Soc. Jpn*, **49**, 8 (1976).
- W. West and B. H. Carroll in "The Theory of the Photographic Process", 3d ed., C. E. K. Mees and T. H. James, Ed., Macmillan, New York, N.Y., 1966 p 233.
- H. Meier, "Spectral Sensitization", Forcal Press, London, 1968.
- W. West and P. B. Gilman, *Photogr. Sci. Eng.*, **13**, 221 (1969).
- H. Gerischer, *J. Electrochem. Soc.*, **113**, 1174 (1966).
- F. Lohmann, *Ber. Bunsenges. Phys. Chem.*, **70**, 87, 428 (1966).
- K. Hauffe and J. Range, *Ber. Bunsenges. Phys. Chem.*, **71**, 690 (1967).
- A. Fujishima and K. Honda, *J. Electrochem. Soc. Jpn*, **40**, 33 (1972).
- W. P. Gomes, T. Freund, and S. R. Morrison, *J. Electrochem. Soc.*, **115**, 818 (1968).
- A. Fujishima, K. Honda, and S. Kikuchi, *Kogyo Kagaku Zasshi*, **72**, 108 (1969).
- A. Fujishima and K. Honda, *Bull. Chem. Soc. Jpn*, **44**, 1148 (1971).
- A. Fujishima and K. Honda, *Seisan Kenkyu*, **22**, 478, 524 (1970).
- A. Fujishima, T. Iwase, T. Watanabe, and K. Honda, *J. Am. Chem. Soc.*, **97**, 4134 (1975).

Akira Fujishima,* Takashi Iwase, Kenichi Honda

Department of Industrial Chemistry, Faculty of Engineering
The University of Tokyo, Hongo, Tokyo, Japan

Received September 4, 1975

Oxidative Deamination of Primary Amines by Copper Halide Nitrosyls. The Formation of Geminal Dihalides¹

Sir:

The properties and reactions of copper halide nitrosyls provide a distinct contrast to those of the better known coordinated metal nitrosyls.² Passing nitric oxide into a mixture of anhydrous copper(II) bromide or chloride in acetonitrile converts the relatively insoluble copper(II) halide into a deep violet-black soluble nitrosyl complex.^{3,4} The nitrosyl stretching frequencies of these nitrosyl complexes (X = Br, ν_{NO} 1865, 1846 cm⁻¹; X = Cl, ν_{NO} 1854, 1837 cm⁻¹)⁶ are characteristically those of linearly coordinated nitrosyls.⁸ When these copper nitrosyl solutions are purged with nitrogen or are opened to an inert atmosphere, however, nitric oxide is evolved and the copper(II) halide is quantitatively recovered. Nitric oxide is, therefore, weakly and reversibly⁹ associated with anhydrous copper(II) bromide and chloride in acetonitrile (eq 1).

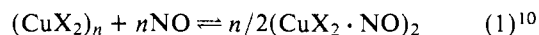

The weak association of nitric oxide with copper(II) bromide or chloride and the relatively low nitrosyl stretching frequencies of the copper halide nitrosyls do not reflect the electrophilic behavior of the coordinated nitrosyl group.¹¹ Reactions of copper halide nitrosyls have been reported to resemble those of the more common nitrosating agents: alcohols form alkyl nitrites,^{12a} secondary amines yield nitrosamines,^{12b} and anilines are converted in a one-step procedure to aryl chlorides and bromides by copper halide nitrosyls in acetonitrile.^{12c} Copper halide nitrosyls also react with sodium azide to form nitrogen, nitrous oxide, and copper(I) halide,¹³ and with ammonia to give nitrogen and copper(I) halide. With aliphatic amines, however, reaction products have been observed to be complex and believed to result from reactions typical of the nitrosonium ion.^{12c}

We have found that primary amines coordinated with copper(II) halides are rapidly oxidized by copper halide nitrosyls primarily to geminal dihalides. Nitrogen and nitrous oxide are the gaseous products from these reactions; copper(I) halide is the principal reduction product. Oxidative deamination of amines by copper(II) halides is not observed in the absence of copper halide nitrosyl. In a typical procedure, a solution of 40 mmol of copper chloride nitrosyl in 50 ml of anhydrous acetonitrile is added dropwise by syphon addition under a slow flow of nitrogen to a well-stirred solution of 10 mmol of the amine complexed with 12 mmol of anhydrous copper(II) chloride in 50 ml of acetonitrile. After stirring the reaction solution for 16 h at room temperature, a 4 M excess of ethylenediamine is added,¹⁴ the resulting solution is poured into aqueous sodium hydroxide-ether, and the reaction products are isolated in the usual manner. Table I gives the yields of geminal dihalides prepared from representative aliphatic amines by this selective method. When the copper bromide system is employed,